

F-0760BW+

LED WASH



FEATURES

1. Powerful brightness: 34870 lux @ 5m, 2.5°
2. Richer colors: 7×60W RGBL pixel control
3. Sharp beam & uniform wash: 2.5°–60° zoom range
4. Smooth, flicker-free for Pro-Dimmer
5. Low noise for noise-sensitive applications
6. Fast movement & accurate positioning
7. Flexible control: CRMX, Art-Net and sACN

55CH	FUNCTION	55CH	FUNCTION
1	Red	28	R1
2	Red 16Bit	29	G1
3	Green	30	B1
4	Green 16Bit	31	L1
5	Blue	32	R2
6	Blue 16Bit	33	G2
7	White	34	B2
8	White 16Bit	35	L2
9	Colour temperature	36	R3
10	Colour Macro	37	G3
11	Strobe	38	B3
12	Dimmer	39	L3
13	Dimmer 16bit	40	R4
14	Pan	41	G4
15	Pan 16Bit	42	B4
16	Tilt	43	L4
17	Tilt 16Bit	44	R5
18	Dimmer Mode	45	G5
19	Reset	46	B5
20	Zoom	47	L5
21	Zoom 16Bit	48	R6
22	Motor Mode	49	G6
23	Dimmer Curve	50	B6
24	Pixel Macro	51	L6
25	Pixel Dimmer	52	R7
26	Pixel Speed	53	G7
27	Pixel Fade	54	B7
		55	L7

Photometrics

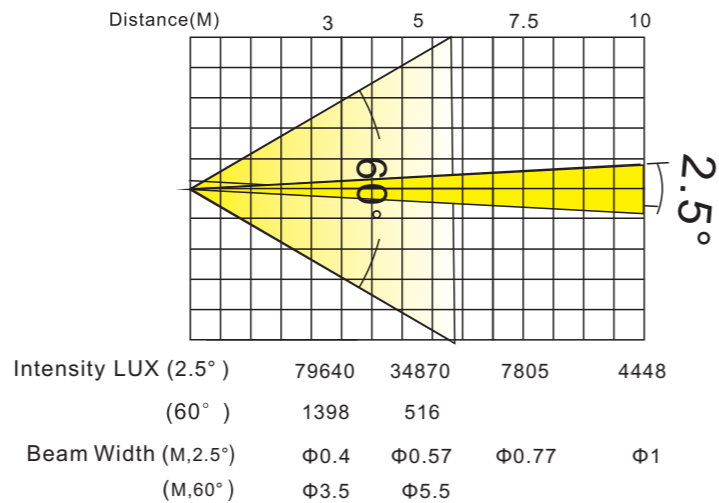

SPECIFICATION

OPTICS

- Light source: 7×60W RGBL LED
- Lifetime: 50000 Hours
- Color temperature: 2500-10000K, linear adjustable

MOVEMENT

- Pan movement: 540° (16 bit)
- Tilt movement: 270° (16 bit)
- Automatic reset function
- High-resolution stepper motors ensure extreme accuracy and smooth movement

COLORS

- Linear RGBL, color mixing with unlimited colors
- dynamic color macro effect with variable speed
- Super uniform light beam with no color shadows and rich saturated and pastel colour-hues

EFFECT SECTION

- Wash, beam, effect modes, multiple macros
- Pixel control
- Zoom: 2.5°-60°, 1:24 ratio
- Dimmer: 0-100% linear dimmer
- Strobe: Electronic strobe, 0.3-20Times/SEC
- Dedicated channel for color temperature setting

CONTROL AND PROGRAMMING

- Control mode: DMX512, Protocols RDM, CRMX Wireless DMX and Art-Net, sACN
- Standard mode: 16/21/23/27/55 channels
- Fan mode: AUTO/FAST/LOW/SUPER LOW

OTHER FUNCTION

- 2.4inch color LCD screen
- High reliability touch button
- Support auto flip display
- Support Multi-language
- Automatic monitoring of light source temperature high temperature automatic protection
- Intelligent cooling system
- DMX512 Software update
- Display light use time
- Low level linearity, flicker free film TV
- 100% brightness without stroboscopic problem
- Menu setting by internal rechargeable battery without power supply (3.7V rechargeable lithium-ion battery)
- Intelligent control of wind speed
- Reverse display
- Manual programming
- Maintenance mode

POWER SUPPLY AND CONNECTIONS

- Input voltage: 100V~240V AC 50/60Hz
- Power consumption: 520W@220V
- Power socket: power connector input&output
- DMX and RDM data in/out: Locking 3-pin/5-pin XLR

HOUSING

- Environmentally friendly flame retardant materials
- High temperature resistant engineering plastics
- Intellectual property rights of appearance and structure design

IP GRADE

- IP:20

DIMENSION

- Product Size: 300 x 212 x 397 MM -11.81"x 8.35"x 15.63"
- Carton size(1in1): 490 x 410 x 320 MM -19.29"x 16.14"x 12.60"
- Flight case size(4in1): 830 x 530 x 620 MM -32.68"x20.87"x 24.41"
- Flight case size(6in1): 1200 x 520 x 600 MM -47.24"x 20.47"x 23.62"

WEIGHT

- Net weight: 9KG

